

REX

PIPE THREADING MACHINE

FP50A/FR50A Series

PARTS LIST

CE UK
CA

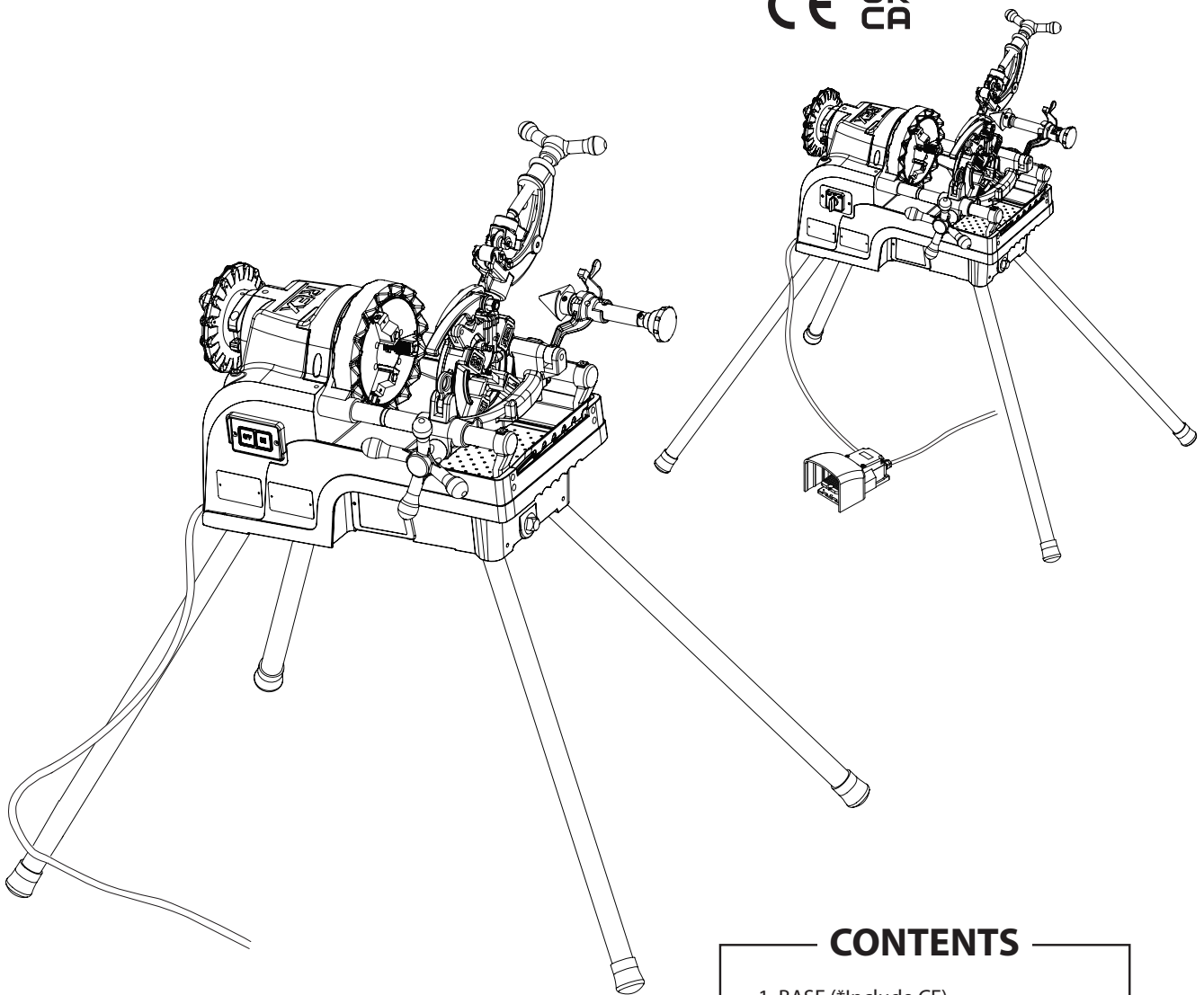

CONTENTS

1. BASE (*Include CE)
2. MAIN SHAFT, MOTOR (*Include CE)
3. MOTOR ASSEMBLY
4. CARRIAGE
5. CUTTER , REAMER

FP50A / FR50A Series - 1. BASE (*Include CE)

Notes:  Same parts are found elsewhere on the page

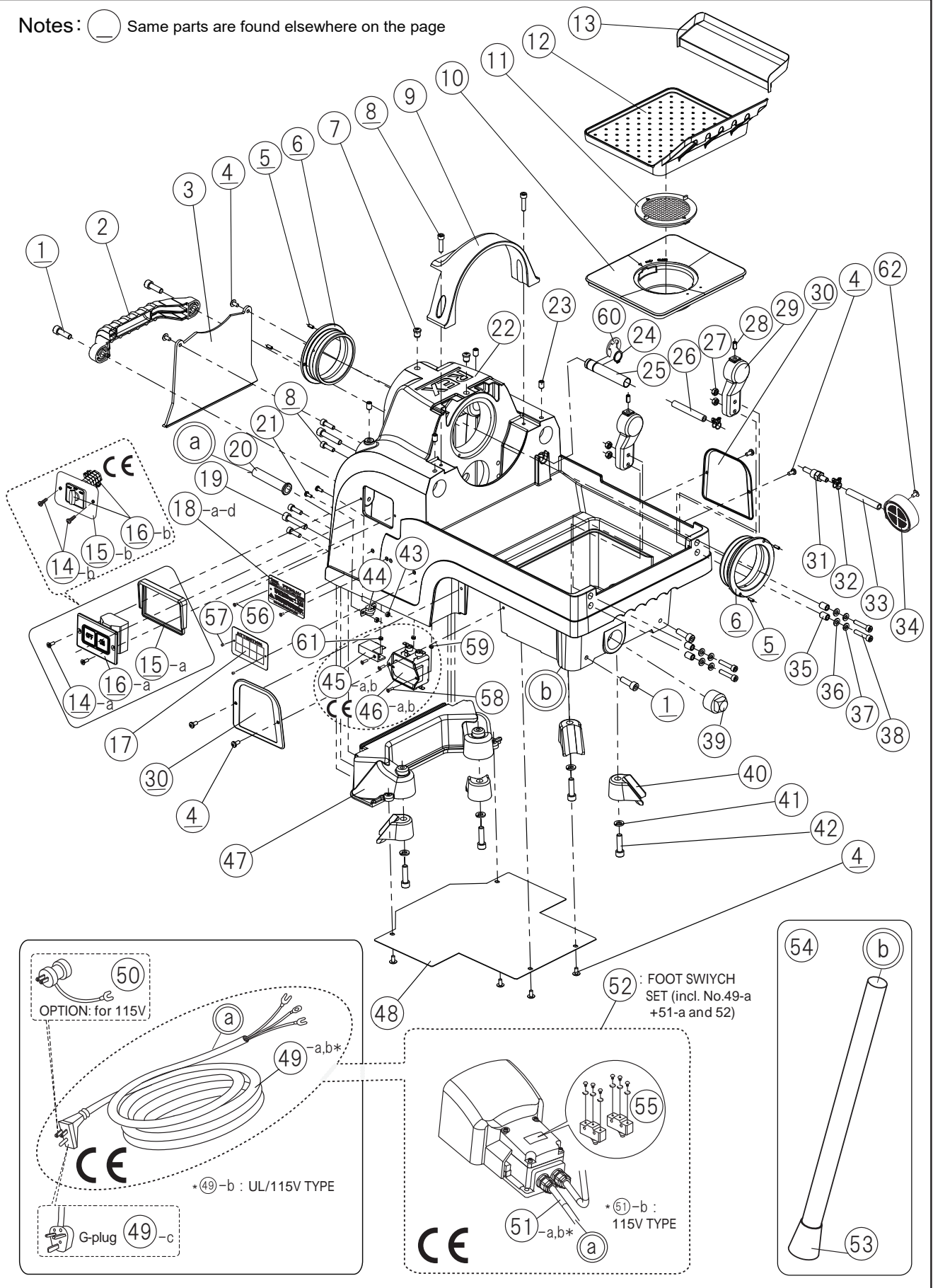

FP50A / FR50A Series - 2. MAIN SHAFT, MOTOR (*Include CE)

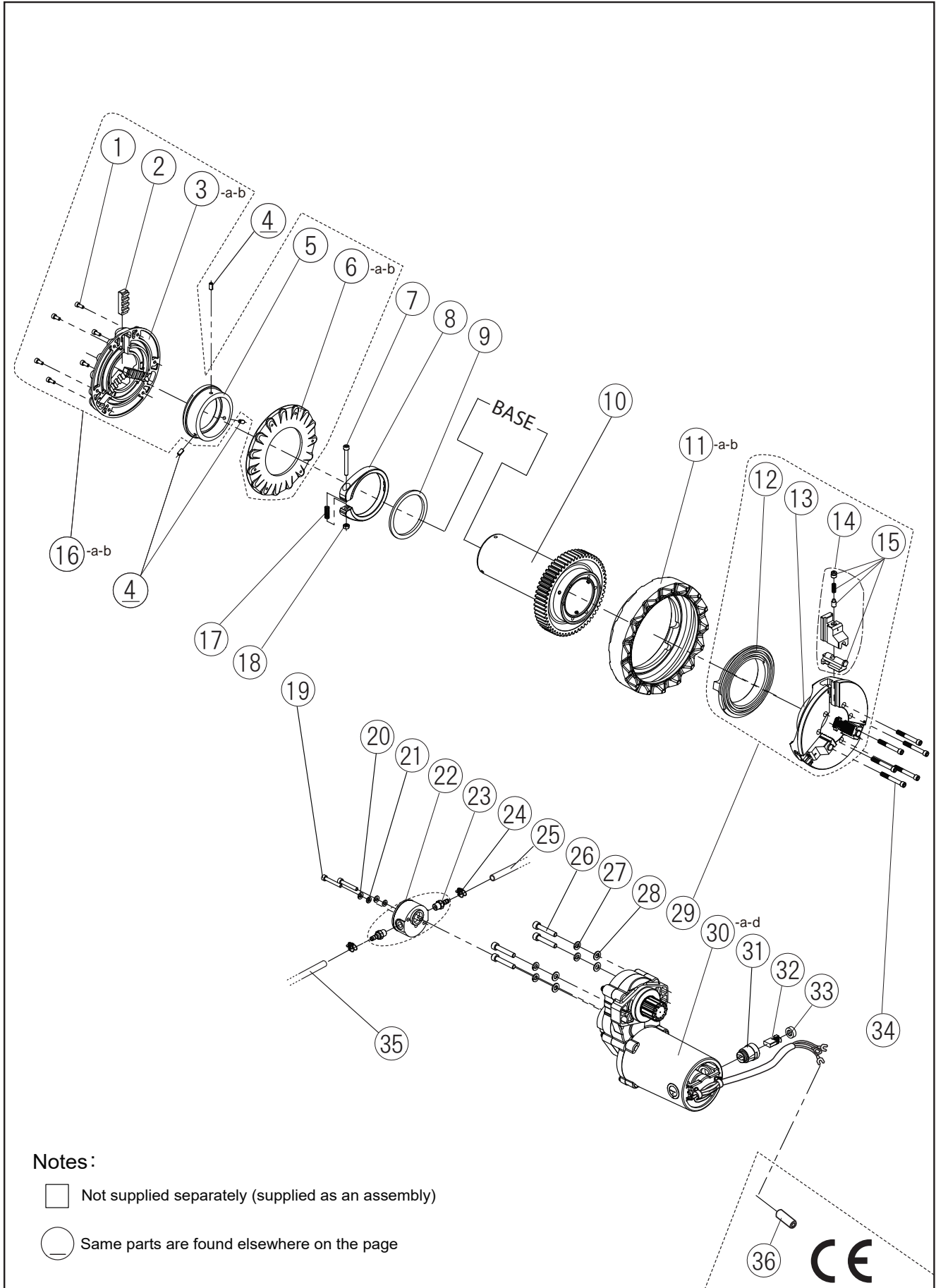

Notes:

□ Not supplied separately (supplied as an assembly)

○ Same parts are found elsewhere on the page



FP50A / FR50A Series - 3. MOTOR ASSEMBLY

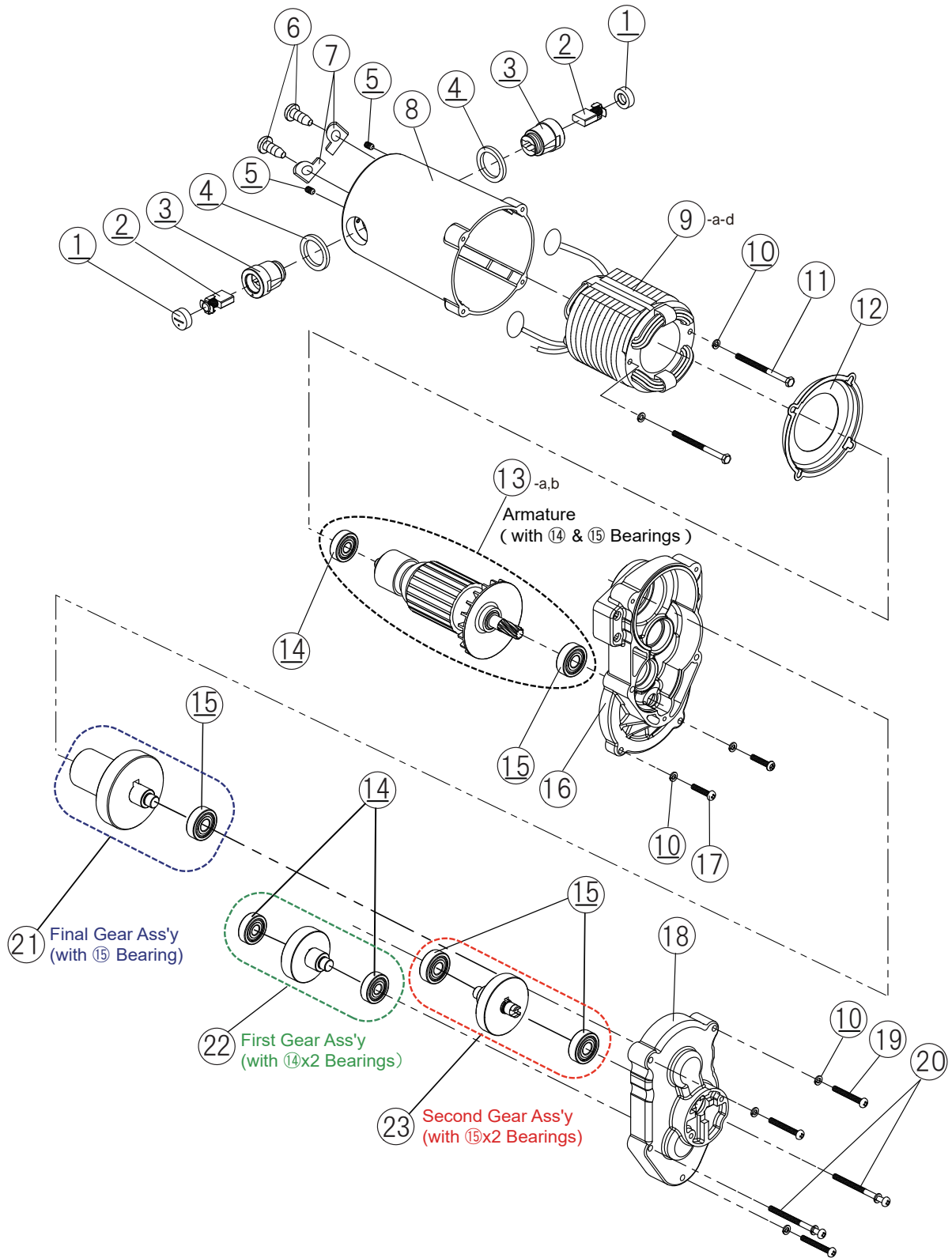

Notes:

○ Same parts are found elsewhere on the page

FP50A / FR50A Series - 4. CARRIAGE

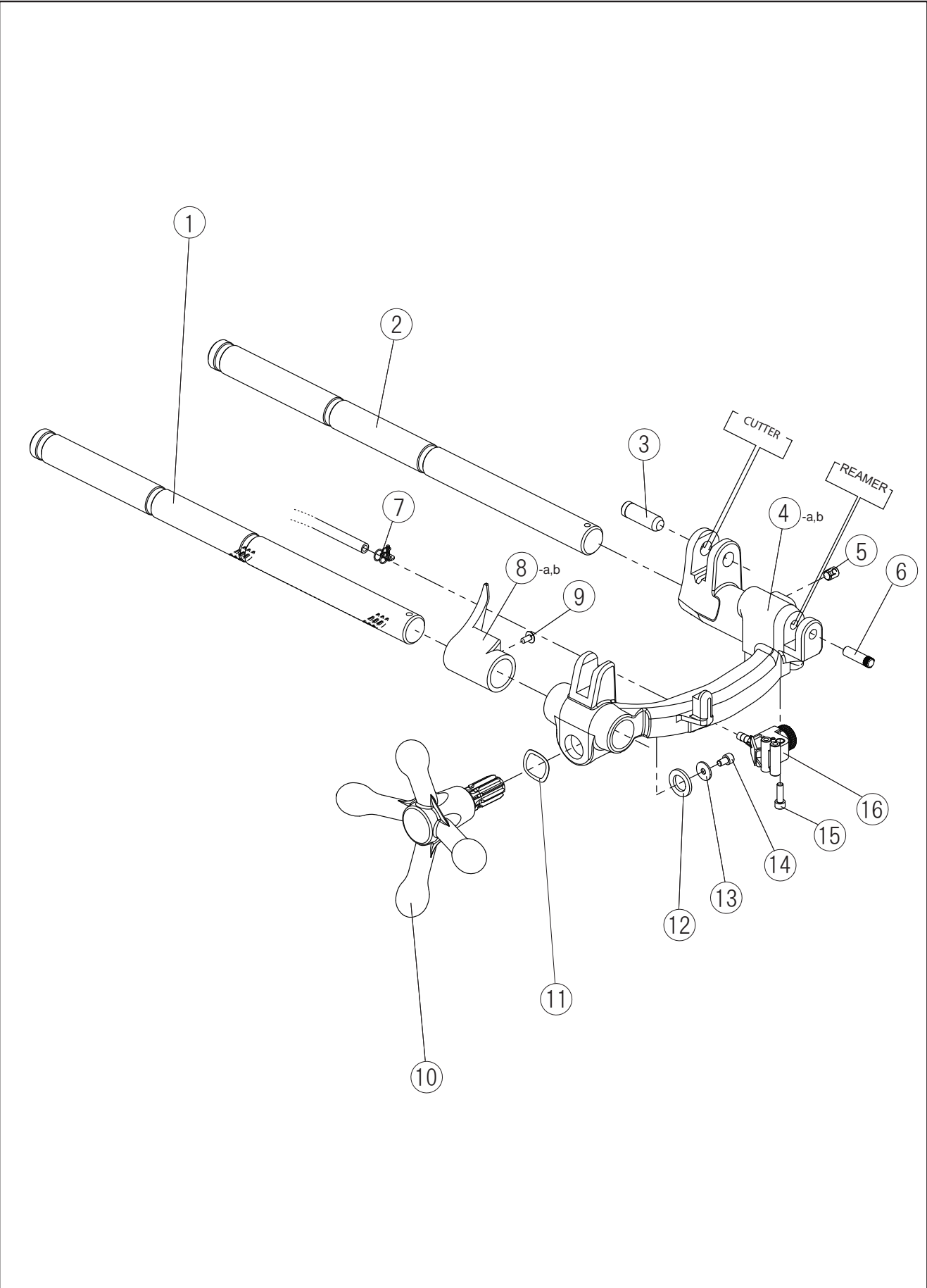

FP50A / FR50A Series - 5. CUTTER, REAMER

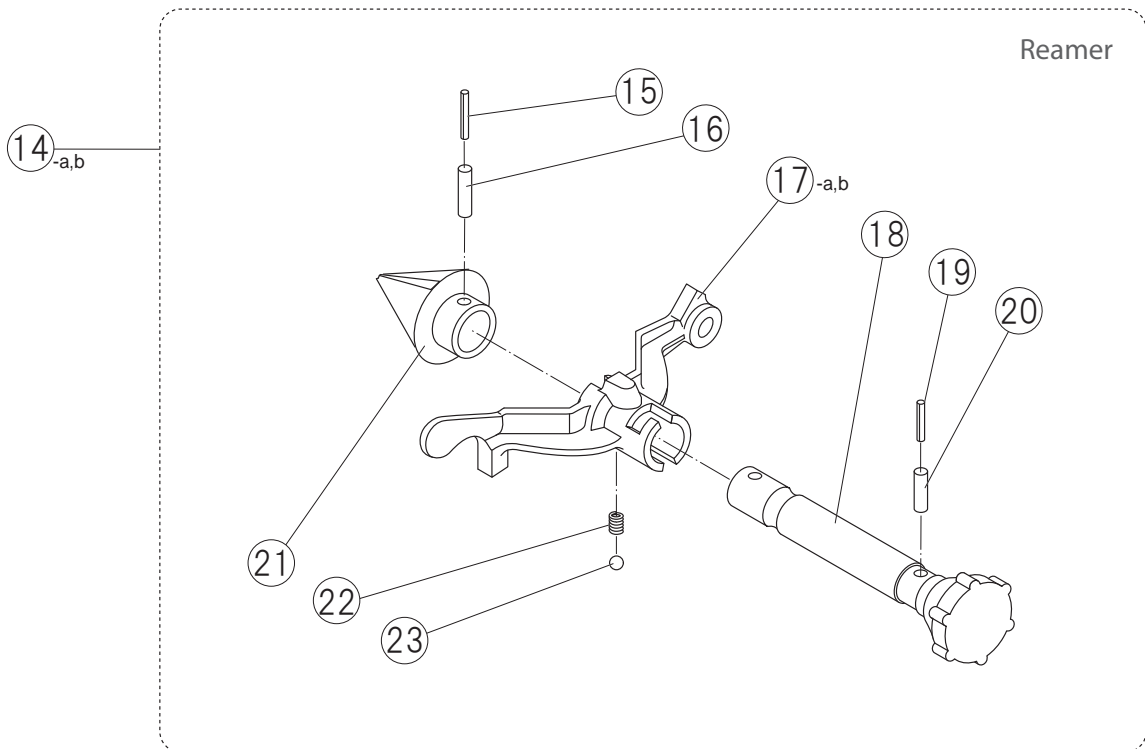
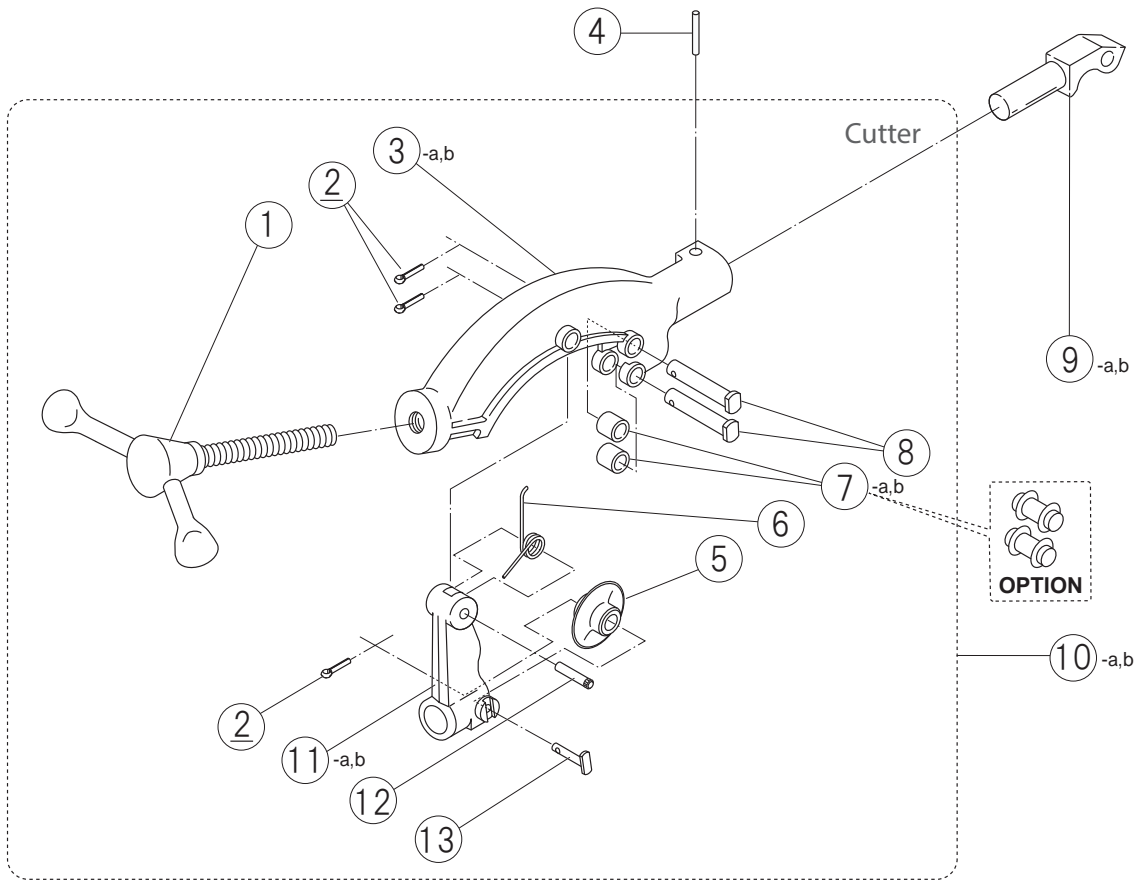

REX

REX INDUSTRIES CO., LTD.

Overseas Sales Section & Factory:

1-9-3, Hishiya-Higashi, Higashi-Osaka 578-0948 Japan

Tel.: +81-(0)72-961-9820 Fax.: +81-(0)72-961-9878

URL <http://www.rexind.co.jp>

Specifications, colour, etc. may be changed without prior notification.

PL-FPR50A-CE1

2303R 0000

Page No.	Item No.	Page Title	CE	REX PARTS NO.	Part Name	Spec.	Q'ty	Remarks
1	1	1.Base		W083	Hex Socket Head Cap Screw	M8×25	4	
1	2	1.Base		N504	Rear Grip		1	
1	3	1.Base		N503	Rear Cover		1	
1	4	1.Base		W252	Pan Head Machine Screw	M5×10	10	
1	5	1.Base		WL41	Roll Pin	4×10	4	
1	6	1.Base		PQ04	Main Shaft Bearing		2	
1	7	1.Base		J009	Grease Nipple		2	
1	8	1.Base		W063	Hex Socket Head Cap Screw	M6×20	6	
1	9	1.Base		PQ02	Gear cover		1	
1	10	1.Base		N514	Tank Upper Cover		1	
1	11	1.Base		N515	Oil Filter		1	
1	12	1.Base		FF17	Scrap Receiver		1	
1	13	1.Base		N624	Oil Pan		1	
1	14-a	1.Base		W4A4	Oval Head Machine Screw	M4×12	2	
1	14-b	1.Base		W546	Oval Head Machine Screw	M4×8	2	
1	15-a	1.Base		N041	Switch Fixed Plate		1	
1	15-b	1.Base	Y	PQ16	Switch Adapter Plate	CE / WH	1	
1	16-a	1.Base		N008	Switch		1	
1	16-b	1.Base	Y	PQ2A	Cam Switch	CE / WH	1	
1	17	1.Base		PQ15	Caution Plate		1	
1	18-a	1.Base		PQ14	Name Plate - FR50A	FR	1	not for sale
1	18-b	1.Base	Y	PQ13	Name Plate - FR50AV CE	CE/FR	1	not for sale
1	18-c	1.Base		PQ12	Name Plate - FP50A	FP	1	not for sale
1	18-d	1.Base	Y	PQ11	Name Plate - FP50AV CE	CE/FP	1	not for sale
1	19	1.Base		W085	Hex Socket Head Cap Screw	M8×40	2	
1	20	1.Base		7021	Cord Bush		1	
1	21	1.Base		W245	Pan Head Machine Screw	M4×20	2	
1	22	1.Base		PQ01	Base Casting		1	
1	23	1.Base		W782	Hex Socket Set Screw	Cup Point M8×10	4	
1	24	1.Base		WW16	Snap Ring	Outside Φ16	1	
1	25	1.Base		FF28	Oil Tube Cover		1	
1	26	1.Base		0411-700	Oil Line Tube G	700mm / Green	1	
1	27	1.Base		WC06	Nut	M6	4	
1	28	1.Base		WL60	Roll Pin	6×12	2	
1	29	1.Base		N013C	Base Support		2	
1	30	1.Base		N520	Side Cover		2	
1	31	1.Base		PN37	Nipple		1	
1	32	1.Base		ZJ50	Pipe Band	10mm	2	
1	33	1.Base		0411-55	Oil Line Tube G (Strainer)	55mm / Green	1	PMK6
1	34	1.Base		N048	Strainer		1	
1	35	1.Base		N057	Support Collar		4	
1	36	1.Base		PQT6	Flat Washer	16x7x1.5	4	
1	37	1.Base		WG06	Spring Washer	M6	4	
1	38	1.Base		W065	Hex Socket Head Cap Screw	M6×30	4	
1	39	1.Base		WA42	Drain Plug	PT1"	1	
1	40	1.Base		N525	Stand Support		4	
1	41	1.Base		WG08	Spring Washer	M8	4	
1	42	1.Base		W08F	Hex Socket Head Cap Screw	M8×30	4	
1	43	1.Base		WC04	Nut	M4	2	
1	44	1.Base		PQ17	Saddle band (Iron/M10)		1	

Page No.	Item No.	Page Title	CE	REX PARTS NO.	Part Name	Spec.	Q'ty	Remarks
1	45-a	1.Base	Y	PM93	Surge Protection Switch	230V CE	1	
1	45-b	1.Base	Y	PM78	Surge Protection Switch	115V CE	1	
1	46-a	1.Base	Y	PM92	Electromagnetic Filter	230V CE	1	
1	46-b	1.Base	Y	PM77	Electromagnetic Filter	115V CE	1	
1	47	1.Base		N524	Stand Base		1	
1	48	1.Base		PQ09	Bottom Cover		1	
1	49-a	1.Base	Y	PM58	Cabtyre Cord	for CE / Standard	1	
1	49-b	1.Base		PQ2E	Cabtyre Cord	for UL	1	
1	49-c	1.Base		NR96	Cabtyre Cord set 220V	G-plug	1set	
1	50	1.Base		4081	Earthed Adapter 115V	115V Non-CE*(Option)	1	
1	51-a	1.Base	Y	PM59	Foot Switch Wire	230V/CE	1	
1	51-b	1.Base		PQ2D	Foot Switch Wire	115V/UL	1	
1	52	1.Base	Y	PQ2G	Foot Switch set	CE	1set	include No.49-a, 51-a
1	53	1.Base		N125C	Leg Cap		4	
1	54	1.Base		N121C	Pipe Stand W/ N125C Leg Cap		4	
1	55	1.Base		PQT7	Micro Switch Set		1set	2pcs/set
1	56	1.Base		W232	Pan Head Machine Screw	M3x6	2	
1	57	1.Base		WN34	Rivet	#4x5	2	
1	58	1.Base		W363C	Oval Socket Head Cap Screw	M3x12	3	
1	59	1.Base		WC03	Nut	M3	2	
1	60	1.Base		WY12	E Ring	12mm	1	
1	61	1.Base		WD01	Nut with washer	M3	1	
1	62	1.Base		WA55	Tapping screw	M5x8	1	

Page No.	Item No.	Page Title	CE	REX PARTS NO.	Part Name	Spec.	Q'ty	Remarks
2	1	2.Main Shaft, Motor		W053	Hex Socket Head Cap Screw	M5×12	6	
2	2	2.Main Shaft, Motor		PM11	Rear Chuck Jaw		1set	3pcs/set
2	3-a	2.Main Shaft, Motor		PM09	Rear Chuck Receptacle	P-type - Red	1	
2	3-b	2.Main Shaft, Motor		PM69	Rear Chuck Receptacle	R-type - Black	1	
2	4	2.Main Shaft, Motor		WM62	Grooved Pin	C6×12	3	
2	5	2.Main Shaft, Motor		PQ03	Rear Scroll		1	
2	6-a	2.Main Shaft, Motor		PM08	Rear Chuck Cover	P-type - Red	1	
2	6-b	2.Main Shaft, Motor		PM68	Rear Chuck Cover	R-type - Black	1	
2	7	2.Main Shaft, Motor		W069	Hex Socket Head Cap Screw	M6×55	1	
2	8	2.Main Shaft, Motor		FF10	Adjustment ring		1	
2	9	2.Main Shaft, Motor		PQ10	Thrust ring		1	
2	10	2.Main Shaft, Motor		PQ24	Main Shaft With Gear		1set	No.10-a-b as a set
2	11-a	2.Main Shaft, Motor		PM06	Hand Wheel	P-type - Red	1	
2	11-b	2.Main Shaft, Motor		PM70	Hand Wheel	R-type - Black	1	
2	12	2.Main Shaft, Motor		NS00	Front Scroll		1	
2	13	2.Main Shaft, Motor		NH00	Chuck Body		1	
2	14	2.Main Shaft, Motor		N0CJS	Chuck Jaw Set		1set	3pcs/set
2	15	2.Main Shaft, Motor		70KS	Chuck Jaw Insert Set		1set	3pcs/set
2	16-a	2.Main Shaft, Motor		PQ07	Rear Chuck Complete Set	P-type - Red	1	
2	16-b	2.Main Shaft, Motor		PQ08	Rear Chuck Complete Set	R-type - Black	1	
2	17	2.Main Shaft, Motor		F030	Spring for Adjustment ring		1	
2	18	2.Main Shaft, Motor		WE16	U Nut	M6	1	
2	19	2.Main Shaft, Motor		W067	Hex Socket Head Cap Screw	M6×40	2	
2	20	2.Main Shaft, Motor		WG06	Spring Washer	M6	2	
2	21	2.Main Shaft, Motor		Wl61	Flat Washer	M6	2	
2	22	2.Main Shaft, Motor		PM30	Gear Pump with Joint (1035)		1	
2	23	2.Main Shaft, Motor		1035	Joint		2	
2	24	2.Main Shaft, Motor		ZJ50	Pipe Band	10mm	2	
2	25	2.Main Shaft, Motor		0411-450	Oil Line Tube G (Intake)	450mm	1	
2	26	2.Main Shaft, Motor		W08B	Hex Socket Head Cap Screw	M8×45	4	
2	27	2.Main Shaft, Motor		WG08	Spring Washer	M8	4	
2	28	2.Main Shaft, Motor		Wl81	Flat Washer	M8	4	
2	29	2.Main Shaft, Motor		N006	Chuck Complete Set	(K-S)	1set	
2	30-a	2.Main Shaft, Motor		PQ1B	Motor	115V / Standard	1	
2	30-b	2.Main Shaft, Motor	Y	PQ1F	Motor	115V / CE	1	
2	30-c	2.Main Shaft, Motor		PQ1A	Motor	230V / Standard	1	
2	30-d	2.Main Shaft, Motor	Y	PQ1E	Motor	230V / CE	1	
2	31	2.Main Shaft, Motor		PMA03	Carbon Brush Holder		1set	2pcs/set
2	32	2.Main Shaft, Motor		PQEE	Carbon Brush		1set	2pcs/set
2	33	2.Main Shaft, Motor		PMA04	Carbon Brush Cap		1set	2pcs/set
2	34	2.Main Shaft, Motor		W075	Hex Socket Head Cap Screw	M7×54	6	
2	35	2.Main Shaft, Motor		0411-700	Oil Line Tube G (feed)	700mm	1	PMK7
2	36	2.Main Shaft, Motor	Y	PM91	Ferrite	CE	1	

Page No.	Item No.	Page Title	CE	REX PARTS NO.	Part Name	Spec.	Q'ty	Remarks
3	1	3.Motor Assembly		PMA04	Carbon Brush Cap		1set	2pcs/set
3	2	3.Motor Assembly		PQEE	Carbon Brush		1set	2pcs/set
3	3	3.Motor Assembly		PMA03	Carbon Brush Holder		1set	2pcs/set
3	4	3.Motor Assembly		PMA44	Stop Plate		2	
3	5	3.Motor Assembly		W753	Hex Socket Set Screw	Cup point M5x8	2	
3	6	3.Motor Assembly		W243	Pan Head Machine Screw	M4x12	2	
3	7	3.Motor Assembly		PMA45	Cord Clip		2	
3	8	3.Motor Assembly		PMA01	Motor Case		1	
3	9-a	3.Motor Assembly		PQDD	Stator Assembly	115V R / Standard	1set	for PQ1B
3	9-b	3.Motor Assembly	Y	PQGG	Stator Assembly	115V R/L CE	1set	for PQ1F
3	9-c	3.Motor Assembly		PQCC	Stator Assembly	230V R / Standard	1set	for PQ1A
3	9-d	3.Motor Assembly	Y	PQFF	Stator Assembly	230V R/L CE	1set	for PQ1E
3	10	3.Motor Assembly		WG05	Spring Washer	M5	7	
3	11	3.Motor Assembly		WZT1	Hex Head Bolt	M5x70	2	
3	12	3.Motor Assembly		PMA02	Fan Casing		1	
3	13-a	3.Motor Assembly		PQBB	Armature with Bearings	115V	1	incl. No.14&15
3	13-b	3.Motor Assembly		PQAA	Armature with Bearings	230V	1	incl. No.14&15
3	14	3.Motor Assembly		Z008	Ball Bearing	#6200ZZ	3	
3	15	3.Motor Assembly		Z006	Ball Bearing	#6201ZZ	4	
3	16	3.Motor Assembly		PQT1	Gear Case		1	
3	17	3.Motor Assembly		W255	Pan Head Machine Screw	M5x25	2	
3	18	3.Motor Assembly		PQT2	Gear Case Cover		1	
3	19	3.Motor Assembly		W258	Pan Head Machine Screw	M5x40	3	
3	20	3.Motor Assembly		PMA05	Pan Head Machine Screw with Captive Washer	M5x70	2	
3	21	3.Motor Assembly		PQT3	Final Gear Ass'y		1	incl. No.15(x1)
3	22	3.Motor Assembly		PQT4	First Gear Ass'y		1	incl. No.14(x2)
3	23	3.Motor Assembly		PQT5	Second Gear Ass'y		1	incl. No.15(x2)

Page No.	Item No.	Page Title	CE	REX PARTS NO.	Part Name	Spec.	Q'ty	Remarks
4	1	4.Carriage		PQ05	Carriage Support Bar A		1	
4	2	4.Carriage		PQ06	Carriage Support Bar B		1	
4	3	4.Carriage		1076	Cutter Arm Stop Pin		1	
4	4-a	4.Carriage		PM88	Carriage	P-type - Silver	1	
4	4-b	4.Carriage		PM89	Carriage	R-type - Black	1	
4	5	4.Carriage		G861	Stopper	Φ10	1	
4	6	4.Carriage		1096	Reamer Holder Stop Pin		1	
4	7	4.Carriage		ZJ50	Pipe Band	10mm	1	
4	8-a	4.Carriage		N200	Safety Collar	P-type - Red	1	
4	8-b	4.Carriage		N081	Safety Collar	R-type - Black	1	
4	9	4.Carriage		W556	Truss Screw	M5×10	1	
4	10	4.Carriage		FF27	Carriage Handle	With Feed Gear Shaft	1	
4	11	4.Carriage		WH26	Wave Washer	26	1	
4	12	4.Carriage		WI87C	Flat Washer	28X17X3 φ16	1	
4	13	4.Carriage		WI63	Flat Washer	19X6X1.6	1	
4	14	4.Carriage		W060	Hex Socket Head Cap Screw	M6×10	1	
4	15	4.Carriage		W06B	Hex Socket Head Cap Screw	M6×25	1	
4	16	4.Carriage		PM55	Oil Tube Connector		1set	

Page No.	Item No.	Page Title	CE	REX PARTS NO.	Part Name	Spec.	Q'ty	Remarks
5	1	5.Cutter, Reamer		PM43	Cutter Handle With Feed Screw		1	
5	2	5.Cutter, Reamer		WN12	Split Pin	#2.3×15	3	
5	3-a	5.Cutter, Reamer		N020	Cutter Frame	P-type - Red	1	
5	3-b	5.Cutter, Reamer		N602	Cutter Frame	R-type - Black	1	
5	4	5.Cutter, Reamer		4072	Cutter Frame Stop Pin	Short	1	
5	5	5.Cutter, Reamer		135076	Cutter Wheel		1	see Product list
5	6	5.Cutter, Reamer		9025	Spring		1	
5	7-a	5.Cutter, Reamer		5074	Cutter Roller		2	
5	7-b	5.Cutter, Reamer		5075	Roller Blade For PLP	for PLP	2	Option
5	8	5.Cutter, Reamer		5079	Cutter Pin	Long	2	
5	9-a	5.Cutter, Reamer		N023	Cutter Arm	P-type - Red	1	
5	9-b	5.Cutter, Reamer		N608	Cutter Arm	R-type - Black	1	
5	10-a	5.Cutter, Reamer		0NCTPS	Cutter Complete Set	P-type - Red	1 set	
5	10-b	5.Cutter, Reamer		0NCNPS	Cutter Complete Set	R-type - Black	1 set	
5	11-a	5.Cutter, Reamer		4067	Cutter Guide	P-type - Red	1	
5	11-b	5.Cutter, Reamer		N603	Cutter Guide	R-type - Black	1	
5	12	5.Cutter, Reamer		9027	Cutter Guide Pin		1	
5	13	5.Cutter, Reamer		2471	Cutter Pin	Short	1	
5	14-a	5.Cutter, Reamer		0NRTPS	Reamer Complete Set	P-type - Red	1 set	
5	14-b	5.Cutter, Reamer		0NRTRS	Reamer Complete Set	R-type - Black	1 set	
5	15	5.Cutter, Reamer		WL59	Roll Pin	5×45	1	Old No.:WLA2 : 4.75×45
5	16	5.Cutter, Reamer		WL87	Roll Pin	8×45	1	
5	17-a	5.Cutter, Reamer		PMK5	Reamer Arm	P-type - Red	1	Old No: RY28/N025
5	17-b	5.Cutter, Reamer		N605	Reamer Arm	R-type - Black	1	
5	18	5.Cutter, Reamer		N027	Reamer Shaft (With Hand Grip)		1 set	
5	19	5.Cutter, Reamer		WL57	Roll Pin	5×35	1	Old No.:WLA1(4.75×35)
5	20	5.Cutter, Reamer		WL86	Roll Pin	8×35	1	
5	21	5.Cutter, Reamer		PM38	Reamer Cone		1	
5	22	5.Cutter, Reamer		5096	Spring	8×10	1	
5	23	5.Cutter, Reamer		WQ08	Steel Ball	8	1	